

KEY FEATURES

- Low Thermal Resistance
- Rugged Optomite 0603 package
- High Brightness
- No UV bleed through
- Broad angular Luminous Emission
- Suited for high reliability applications

APPLICATIONS

- Mobile Phone Keypad
- Panel, button, switch indicators.
- Backlighting
- Signage
- Signals and Marker Lights

The UPWLEDxx product incorporates Microsemi's unique, patented packaging concept to improve the homogeneous distribution of white light. The Optomite package has low thermal resistance, <math><110^{\circ}\text{C}/\text{W}</math>. The package gives a broad luminous emission, >math>170^{\circ}</math>. The packaging characteristics lend themselves to increased life, critical to many white applications.

IMPORTANT: For the most current data, consult MICROSEMI's website: <http://www.microsemi.com>

**ABSOLUTE MAXIMUM RATINGS AT 25° C
(UNLESS OTHERWISE SPECIFIED)**

Parameters	Symbol	Value	Unit DC
Forward dc Drive Current	I_F	30	mA
Peak Forward Current (non-repetative)	I_{FP}	100	mA
LED Operating Junction Temperature	T_j	-40 to +150	$^{\circ}\text{C}$
Reverse Voltage	V_R	8	V
Power Dissipation @ 30mA	P_D	125	mW
Operating Temperature	T_{OPR}	-40 to +125	$^{\circ}\text{C}$
Storage Temperature	T_S	-45 to +150	$^{\circ}\text{C}$
Electrostatic Discharge	ESD	1000	V
ESD classification		Class 2	
Solder Reflow Peak Temperature (Solder 10")		225	$^{\circ}\text{C}$

**THERMAL CHARACTERISTICS
(UNLESS OTHERWISE SPECIFIED)**

Thermal Resistance	Symbol	Value	Units
Junction-to Soldering Point	$R_{\theta JS}$	110	$^{\circ}\text{C}/\text{W}$

NOTE: The "x" trailer in the part number refers to the intensity bin followed by color rank. (see table). For operation of these LEDs in pulse mode applications, devices may be used in conjunction with Microsemi LX1992LED Drivers.

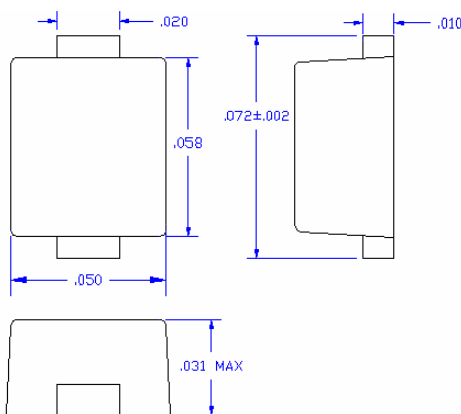
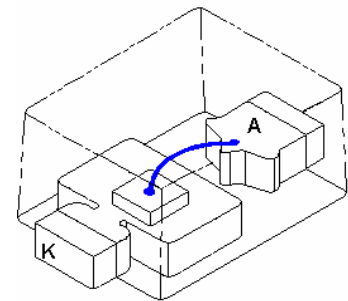

Anode is the smaller of the two base pads.

Mount to circuit using 60/40 Pb/Sn or equivalent.

Maximum solder melt exposure temperature is 225°C for 10 seconds.



HIGH BRIGHTNESS WHITE LED

PRODUCT PREVIEW

ELECTRICAL PARAMETERS @ 25°C

Characteristic	Symbol	Test Conditions	Min	Typ.	Max	Units
Radiant Intensity	I_E	dc Drive Current = 20mA		550		$\mu\text{W/sr}$
Luminous Intensity, (Bin S)	I_V	dc Drive Current = 20mA	180	200	220	mcd
Luminous Intensity, (Bin T)		dc Drive Current = 30mA		250		
Luminous Intensity, (Bin U)		dc Drive Current = 50mA		320		
Dominant Wavelength	λ_{DOM}	Dc Drive Current = 20mA		488		nm
Peak Wavelength	λ_{PK}	dc Drive Current = 20mA		460		nm
Color Rank a Chrom x Chrom y		dc Drive Current = 20mA	0.295 0.31	0.305 0.33	0.32 0.35	
Color Rank b Chrom x Chrom y			0.30 0.32	0.315 0.34	0.325 0.36	
Color Rank c Chrom x Chrom y			0.32 0.32	0.33 0.33	0.345 0.36	
Color Rank d Chrom x Chrom y			0.34 0.34	0.35 0.35	0.365 0.38	
Other color ranks are available upon request. Consult factory.						
Angle Coverage to 50% points	$\alpha_{1/2}$	dc Drive Current = 20mA to 50mA	140	150		deg.
			Φ_V typical		Φ_E typical	
Bin (S)	Φ_V	dc Drive Current = 20mA	500	mlm	1.75	mW
Bin (T)		dc Drive Current = 30mA	625		2.75	
Bin (U)		dc Drive Current = 50mA	1000		3.75	
Luminous Flux, Φ_V	Φ_E	dc Drive Current = 20mA	625		2.25	
Radiant Flux, Φ_E		dc Drive Current = 30mA	850		3.5	
		dc Drive Current = 50mA	1300		4.5	
Forward Voltage	V_F	dc Drive Current = 20mA dc Drive Current = 30mA dc Drive Current = 50mA		3.6 3.9 4.5	3.9 4.2 4.9	V
Reverse Leakage Current	I_R	Reverse Voltage = 5 V dc			10	μA

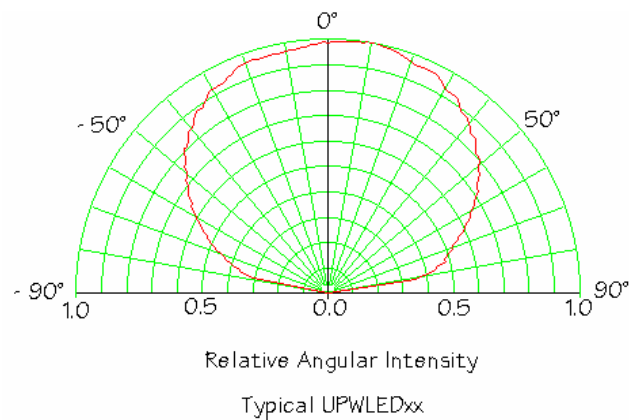
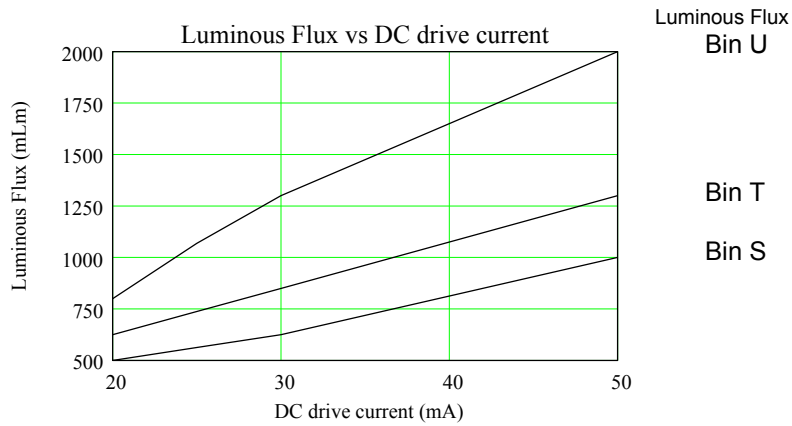
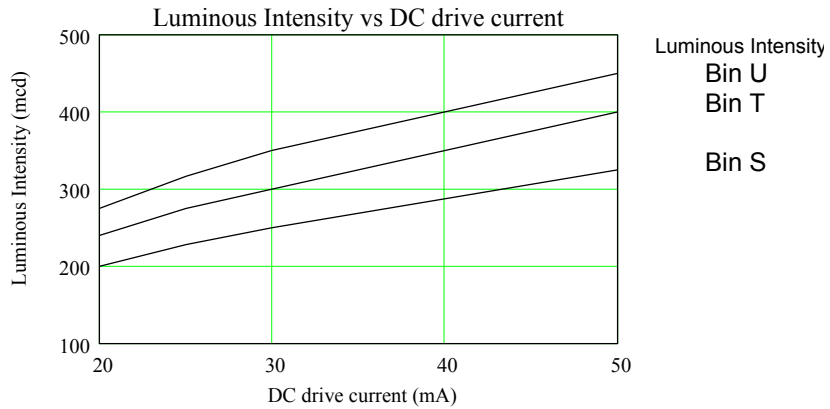

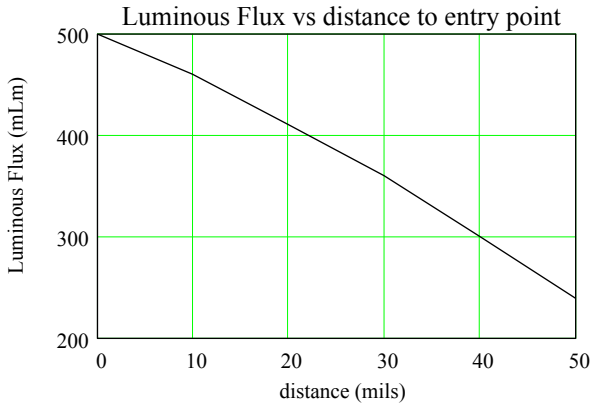

Luminous Flux at ID=20mA in mLm as a function of distance in mils between Optomite top surface and entry point of Light pipe. (scale as appropriate for bins T and U)

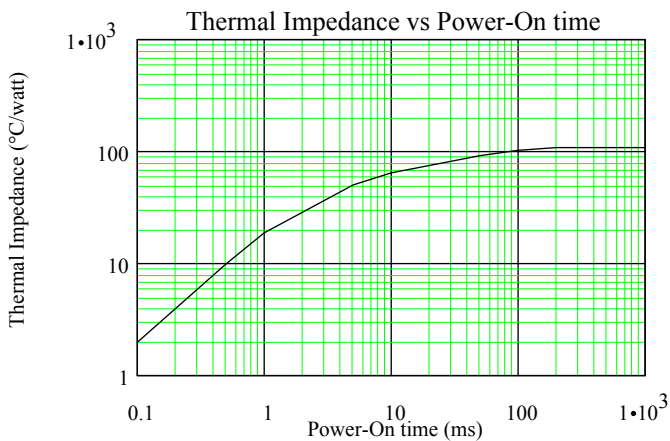

Steady State Thermal Resistance Junction-to-Optomite base metal ~ 110°C/watt
 Steady State Thermal time constant ~ 20ms

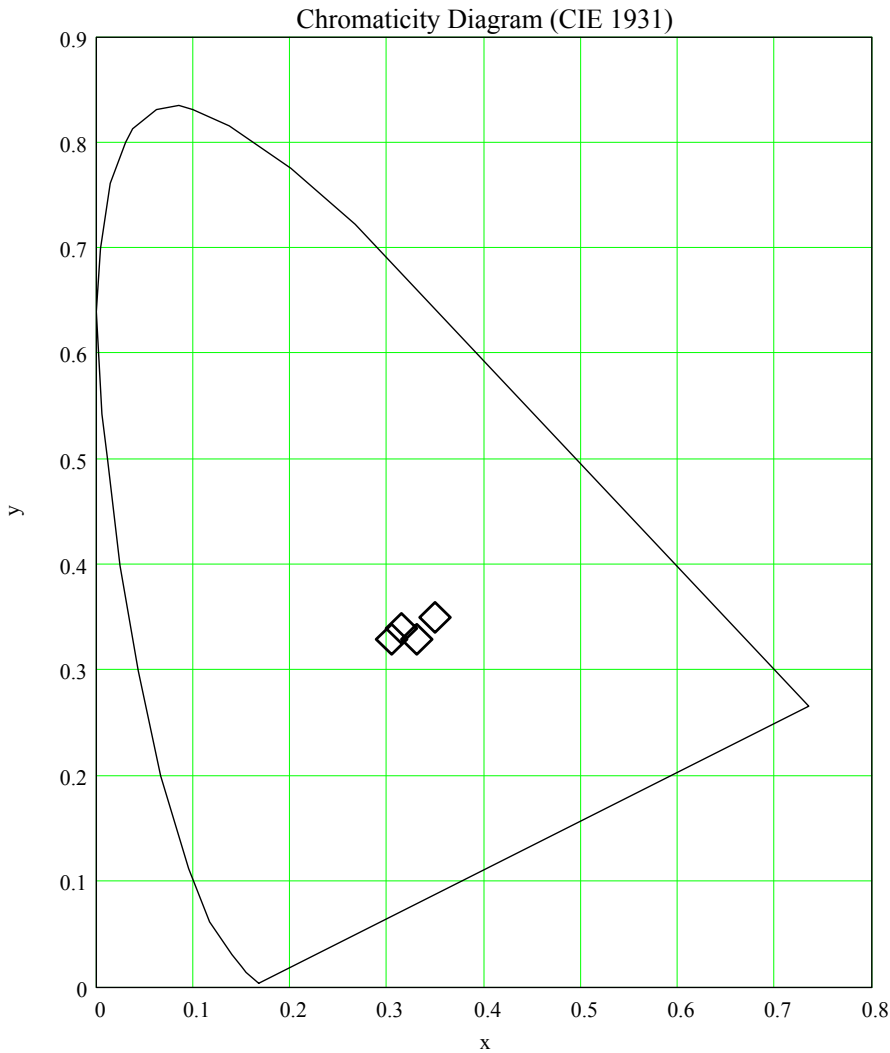

Diamonds indicate center points of color ranks *a*, *b*, *c* and *d*

Conversion of 1931 *x y* coordinates to 1960 *u v* coordinates:

$$u = 4x/(-2x + 12y + 3), \quad v = 6y/(-2x + 12y + 3)$$

Conversion of 1960 *u v* coordinates to 1931 *x y* coordinates:

$$x = 3u/(2u - 8v + 4), \quad y = 2v/(2u - 8v + 4).$$

Consult factory for optional Intensity and color ranking.

RELIABILITY STATUS

Test	Conditions	Duration	No. Rejects
Resistance to Solder heat	$T_a = 230^{\circ}\text{C}$ $+5^{\circ}\text{C}, -0^{\circ}\text{C}$	5 to 6 seconds	0/15
Vibration variable Frequency	20 G (min); 20Hz to 2,000Hz each axis; x, y and z	4 min. each axis	0/15
Storage Bake	$T_a = 100^{\circ}\text{C}$	1,000 hrs	0/35
Temp. Cycle	$T_a = +65^{\circ}\text{C}$ to -55°C	225 cycles	0/35
Burn-In	$I_D = 20 \text{ mA}$, $T_a = 25^{\circ}\text{C}$	2,000 hrs	0/35
Hi Humid/Temp	$T_a = 85^{\circ}\text{C}$, RH=85%, no bias	500 hrs	0/15

Note: Accept devices determined by reduction no greater than 70% of initial values

SPICE MODEL:

```
.model UPWLEDxx D(Is=1E-30 N=1.923 Rs=32.09 Eg=3.6 Cjo=63.87p
+      M=.1513 Vj=2.02 Fc=.5 Isr=1.304m Nr=3.4Meg Bv=12 lbv=369.5u
+      Tt=432.8n Xti=5)
```

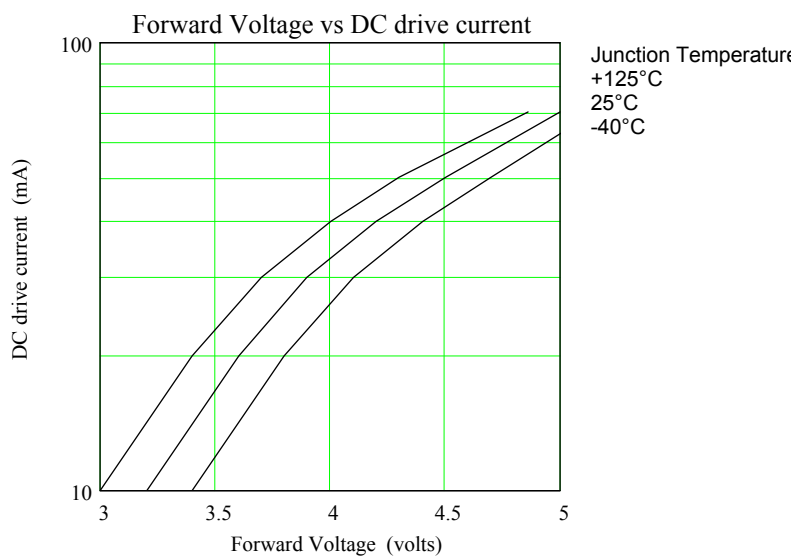

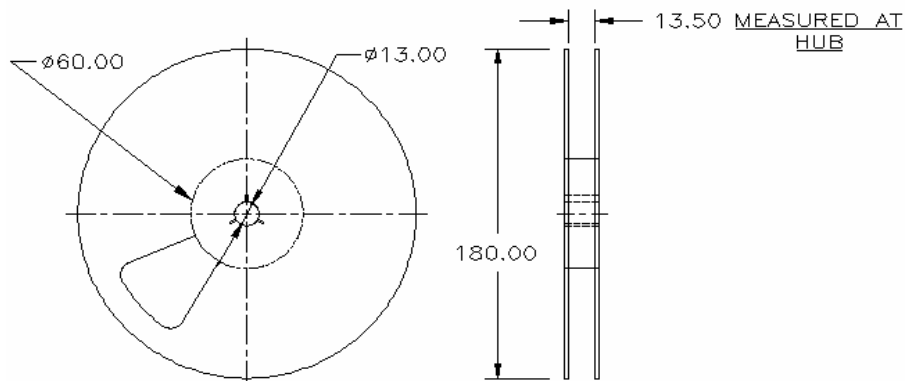
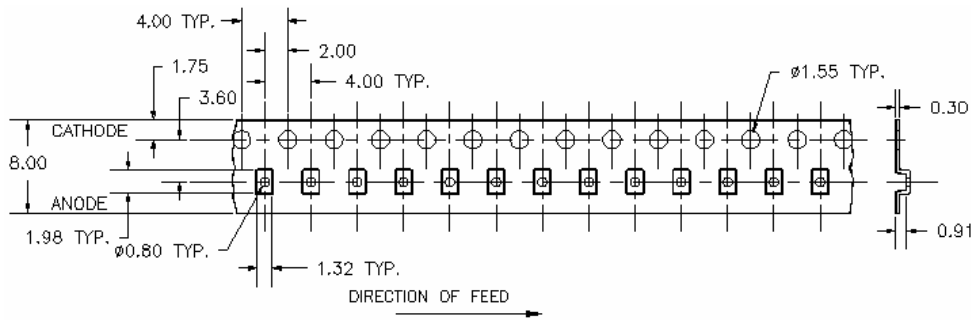
Tape and Reel (metric)**3,000 units /reel**

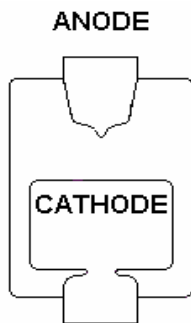

Bottom view of Optomite 0603 package

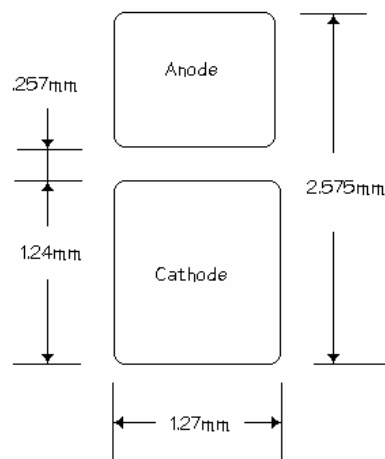

Mounting footprint, Copper (note: Silver plating will enhance Luminous Intensity)

CALCULATION FOR SAFE OPERATION ABOVE dc max. rating:

The power dissipation must be held at a level to maintain the junction below the maximum specified operating temperature.

Duty cycle control may be used to establish the safe operating condition using a train of pulses.

LED Junction temperature may be calculated by use of the following:

$$T_J := T_{Case} + V_F \cdot I_{Dpk} \cdot \left[\frac{t_p \cdot R_{\theta JS}}{\tau} + \left(1 - \frac{t_p}{\tau} \right) \cdot Z_{\theta t + t_p} - Z_{\theta t} + Z_{\theta tp} \right]$$

T_{Case} is at a specified temperature. V_F and I_{Dpk} values are read off graph of forward voltage vs drive current. t_p and τ are set by the on-time and pulse period of the drive circuit. Thermal Impedances (Z_{θ}) and Thermal resistance (R_{θ}) values are read from Thermal Impedance graph.

Example:

Pulse repetition rate, PRR, is 1kHz. (Period, $\tau=1ms$)

Peak current, $I_{Dpk} = 70mA$.

Duty cycle = 25%. Thus, $t_p = 250\mu S$

Case temperature, T_{Case} , is maintained at 40°C maximum.

Determine junction temperature.

Step 1. Find V_F from graph. ($V_F = 4.9V @ I_{Dpk} = 70mA$. Peak power dissipation is 343mW.)

Step 2. Substitute the values for the Z_{θ} @ indicated times, as read from the thermal impedance graph:

$Z_{\theta 1.25ms}$	25° C/W
$Z_{\theta 1ms}$	20° C/W
$Z_{\theta 250\mu s}$	2° C/W (extrapolated)

Calculated value of Junction temperature for this application is $T_J = 51^{\circ}C$